

MICROH

PROFESSIONAL PRODUCTS

www.microhpro.com



USER MANUAL

TITAN RGB 1.5

Keep this manual for future reference.

TABLE OF CONTENTS

1. INTRODUCTION AND UNPACKING	1
2. SAFETY INSTRUCTIONS	1-2
3. OPERATION INSTRUCTIONS	2-3
4. MOUNTING AND INSTALLATION	3-4
5. DMX-512 CONTROL CONNECTIONS	4-5
6. MENU NAVIGATION	5
7. PHOTOMETRIC DATA	6
8. DMX CHANNELS	6-7
9. KEY FEATURES	7
10. TECHNICAL SPECIFICATIONS	8
11. MAINTENANCE AND CLEANING	9

1. INTRODUCTION AND UNPACKING

Thank you for purchasing the MICROH TITAN RGB 1.5 laser system. For your own safety and knowledge, please read this manual before installing or operating the device. This manual covers the important information on installation and applications. Please install and operate the fixture according to instructions. Meanwhile, please keep this manual for future reference.

The MICROH LED TITAN RGB 1.5 laser is made of a new type of high temperature cast aluminum casing. The fixture is designed and manufactured strictly following CE standards, complying with international standard DMX512 protocol. This fixture is applicable but not limited to large-scale live performances, theater, studio, nightclubs and discos.

The MICROH TITAN RGB 1.5 laser system uses 3 coloured laser diodes that are carefully aligned with the internal scan mirrors. Please carefully unpack it when you receive the fixture and check if it was damaged during the transportation. And please check whether the following items are included inside the box:

Fixture – One Power Cord – One Bracket Set – One User Manual – One

2. Safety Instructions



This device has left the factory in perfect condition. In order to maintain this condition and to ensure safe operation, it is absolutely necessary for the user to follow the safety instructions and warning notes written in this user manual.



Important:

Damages caused by the disregard of this user manual are not subject to warranty. The dealer will not accept liability for any resulting defects or problems.

If the device has been exposed to temperature changes, do not switch it on immediately. The arising condensation could damage the device. Leave the device switched off until it has reached room temperature, and is dry.

This device falls under protection-class I, therefore it is essential that the device be grounded. The electrical connection must be carried out by a qualified technician.

The device should only be used with rated voltage and frequency. Make sure that the available voltage is not higher than 120V as stated at the end of this manual.

Make sure the power cord is never crimped or damaged in any way, as this could cause shock and damage. If your power cord is damaged in any way, please purchase a new cable from your local MICROH dealer. Always disconnect power, when the device is not in use or before cleaning it. Never pull out the plug by tugging the power cord.

During initial start-up, some smoke or smell may arise. This is a normal process, and does not necessarily mean that the device is defective. It should decrease gradually. Please do not project the beam onto combustible substances.

Fixtures cannot be installed on or near combustible substances. Keep more than 50cm distance from wall for proper ventilation and air flow. If your fixture is or has become damaged in any way, it shall be exclusively replaced or repaired by the manufacturer to avoid any hazard.



CAUTION!

Never touch the device during operation!
The housing may heat up



CAUTION!

Never look directly into the light source,
as sensitive persons may suffer an epileptic shock.



CAUTION!

The electric connection must only be carried out by a qualified electrician.



A Class 3B laser is hazardous to eyes, if exposed directly. Diffused reflections such as from paper or other matte surfaces are not as harmful.

3. OPERATION INSTRUCTIONS

- Do not turn on the fixture if it has been through severe temperature differences. Damage may occur to the fixture. Wait until unit is at room temperature to operate.
- The unit should be protected from any tremor or agitation during transport.
- Do not expose the fixture in any excessive heat, moisture or any environment with too much dust when installing. Do not lay any power cables on the floor. It may cause electronic shock or damage to persons or equipment.
- Make sure to attach the safety chain and ensure the screws are properly screwed in when installing the fixture.
- Make sure the lens is in good condition. It is recommended to replace the unit if there are any damages or severe scratches.
- Make sure the fixture is operated and installed by qualified personnel.
- Keep the original packaging in case of defective product.
- Any non-manufacturer additions, modifications or changes in any way will void all warranty.

- Please do not attempt to open unit. It is only to be serviced by an authorized technician. If this occurs, or is apparent, the warranty will be voided.
- The fixture's warranty will be voided if there are any malfunctions from not following the user manual or any illegal operation (shock short circuit, electronic shock, lamp broke, etc.)
- The Titan RGB 1.5 has a feature where you can track the overall usage of the fixture (fixture hours)

MASTER/SLAVE MODE

- To run the TITAN RGB 1.5 in master/slave mode, the unit must be set to either "AUTO" or "SOUND ACTIVE" mode. The unit must be linked with 3pin XLR to the next fixture. All SLAVE units must be set to "SLAV" through the on board menu. Once selected, press ENTER to confirm.

AUTO-RUN MODE

- To run the TITAN RGB 1.5 in AUTO mode, you must set the unit to "AUTO-PLAY" using the on board menu. Once selected, press ENTER to confirm.

SOUND ACTIVE MODE

- To run the TITAN RGB 1.5 in sound active mode, you must set the unit to "AUDI" using the on board menu. Once selected, press ENTER to confirm.

DMX MODE

- To control the TITAN RGB 1.5 via DMX, select "dxxx" on the display. By using the UP and DOWN buttons select your desired DMX address and press ENTER to confirm. The TITAN RGB has a total 12 channels of DMX.

ILDA (PC CONTROL) MODE

- To run the TITAN RGB 1.5 in IDLA mode or (PC CONTROL MODE) simply connect your ILDA signal cable to the DB25 jack located on the rear of the unit, and the unit will automatically recognize. NOTE: when ILDA is connected, it supersedes all modes.

4. MOUNTING AND INSTALLATION

Caution: For added protection, mount the fixtures in areas outside walking paths, seating areas, or in areas were the fixture might be reached by unauthorized personnel. Before mounting the fixture to any surface, make sure that the installation area can hold a minimum point load of 10 times the device's weight. Fixture installation must always be secured with a secondary safety attachment, such as an appropriate safety cable. Never stand directly below the device when mounting, removing, or servicing the fixture.

Whether installing inverted on a truss or ceiling, or set on a flat level surface (see illustration below). Be sure this fixture is kept at least 0.5m (1.5 ft) away from any flammable materials (decoration etc.). Always use and install the supplied safety cable as a safety measure to prevent accidental damage and/or injury in the event the clamp fails.

Mounting Points: Overhead mounting requires extensive experience, including calculating working load limits. A knowledge of the installation material being used, and periodic safety inspection of all installation material and the fixture are all imperative and should only be performed by a qualified technician. Improper installation can result in bodily injury and damage.

Be sure to complete all rigging and installation procedures before connecting the main power cord to the appropriate wall outlet.



Regardless of the rigging option you choose for your MICROH TITAN RGB 1.5 wash fixture, always be sure to secure your fixture with a safety cable. The fixture provides a built-in rigging point for a safety cable on the hanging bracket as illustrated above. Be sure to only use the designated rigging point for the safety cable and never secure a safety cable to a carrying handle. Please see picture below.



5. DMX-512 CONTROL CONNECTIONS

This fixture complies with international USITT DMX standards and can be used with either a 3 pin or 5 pin DMX connector. Plug in the provided 3 pin XLR cable to the female 3-pin XLR output of your controller and the other side to the male 3-pin XLR input of the MICROH TITAN RGB 1.5. To connect the units to DMX, you must daisy chain the fixtures together as referred in the diagram below. Always end your DMX-512 connection with a DMX terminator.

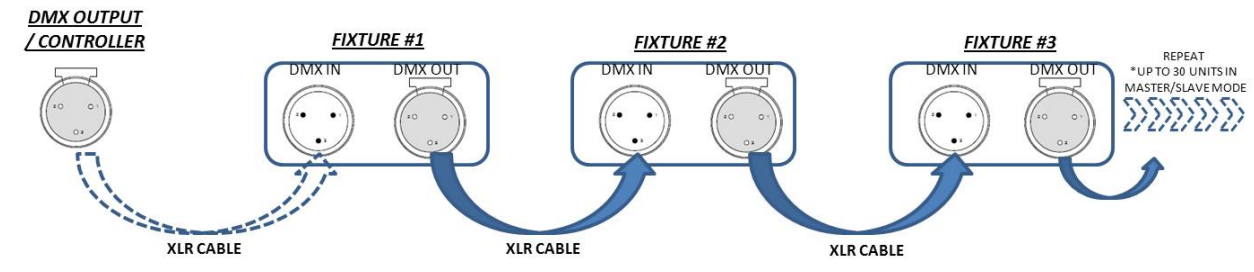



For installations where the DMX cable has to run a long distance, or is in an electrically noisy environment, it is recommended to use a DMX terminator. This helps in preventing corruption of the digital control signal by electrical noise. The DMX terminator is simply an XLR plug with a 120 Ω resistor connected between pins 2 and 3, which is then plugged into the output XLR socket of the last fixture in the chain. Please see illustrations below.

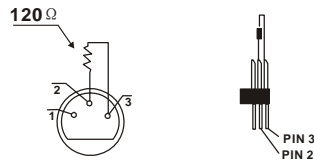

6. MENU NAVIGATION

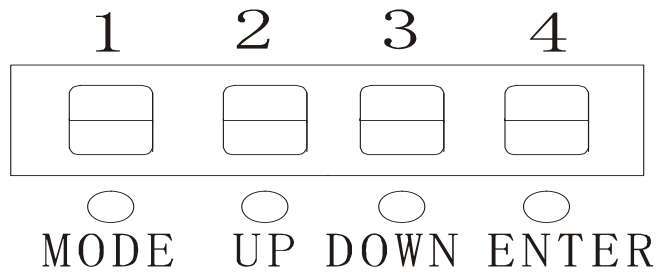

MODE FUNCTIONS

'Audi': Sound Control

'Auto': Auto-run Control

'dxxx': DMX512 Control (The 'xxx' is the address code. Press UP or DOWN to set the address)

'SLAV': Slave Control (The slave unit will do the same effect as master unit.)

'XXXX': Total running time. (This mode displays the total fixture hours that the unit has been in operation.)

7. PHOTOMETRIC / WAVE LENGTH DATA

Red650nm / Green 532nm / Blue450nm

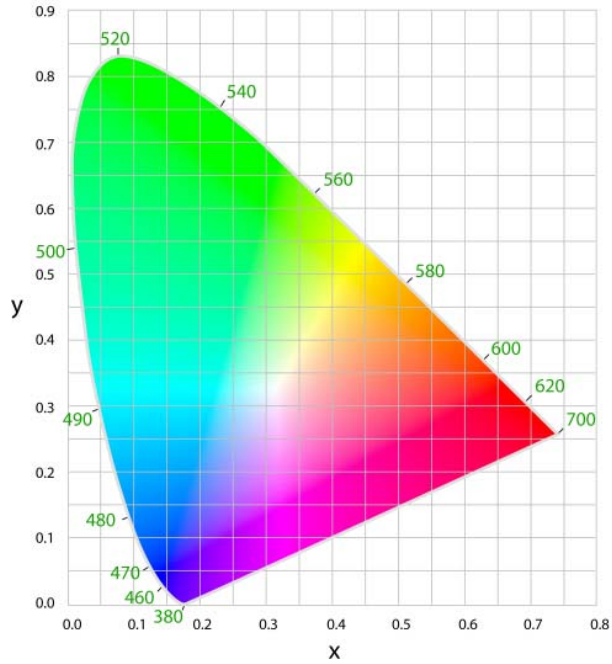

8. DMX CHANNELS

Channel No		DMX512 fig.	Content
Channel 1	Control Mode	0-49	Sound Control
		50-99	Auto Beam
		100-149	Auto Animation
		150-255	Manual
Channel 2	Colour Select	0	Laser Off
		1-255	Change Colour
Channel 3	Pattern Select	0-255	Patterns
Channel 4	Vertical Movement	0-127	Manual
		128-191	From Slow to Fast
		192-255	From Fast to Slow
Channel 5	Horizontal Movement	1-127	Manual
		128-191	Move From Right to Left
		192-255	Move From Left to Right

Channel 6	Vertical Rotation	0-255	From Slow to Fast
Channel 7	Horizontal Rotation	0-255	From Fast to Slow
Channel 8	Rotate	0-127	Manual
		128-191	Anticlockwise Rotation
		192-255	Clockwise Rotation
Channel 9	Zoom	0	Static
		1-85	From Small to Big
		86-170	From Big to Small
		171-255	Auto Zoom
Channel 10	Pattern Size	0	Default Size
		1-255	Small to Big
Channel 11	Spot and Line	0-255	Line to Spot
Channel 12	Flash Speed	0-22	Slow to Fast

9. KEY FEATURES

- RGB Colour Mixing DPSS Diodes (Red650nm, Green 532nm, Blue450nm)
- Pre-Programmed Beam Shows and Animations (Total of 128)
- On-Board Digital Display
- Controllable via DMX (3 Pin XLR)
- IDLA Input for PC Control
- High Speed Quality 20-25K Scan Motors (Max 20,000 pps)
- Eyebolt for Safety Support, Will Support 10 times Weight of Fixture
- Air Cooled
- 1.5W Total Laser Output (R800mw + G200mw + B500mw)
- DMX, ILDA, Sound, Auto, Master/Slave Run Modes
- 12 DMX Channels

10. TECHNICAL SPECIFICATIONS

MODEL: TITAN RGB 1.5

LASER DIODE: DPSS, Red650nm, Green 532nm, Blue450nm

SCANNER: 20-25 Kpps

SCANNING ANGLE: $\pm 30^\circ$

COOLING SYSTEM: Fan

MAX RUN TIME: Approximately 4 Hours

WARM-UP TIME: < 15 Minutes

WORKING TEMPERATURE: $10^\circ \sim 35^\circ \text{C}$

VOLTAGE: 120VAC 60Hz

FUSE: 250VAC 2A

MAX: 360W

DIMENSIONS: 18.19" x 13.78" x 6.3" / 462 x 350 x 160 mm

NET WEIGHT: 33.07 lbs / 15kgs

GROSS WEIGHT: 39.68 lbs / 18kgs

WARRANTY: 2 Year Limited Warranty. The Laser diodes are covered under a 6 month replacement warranty.

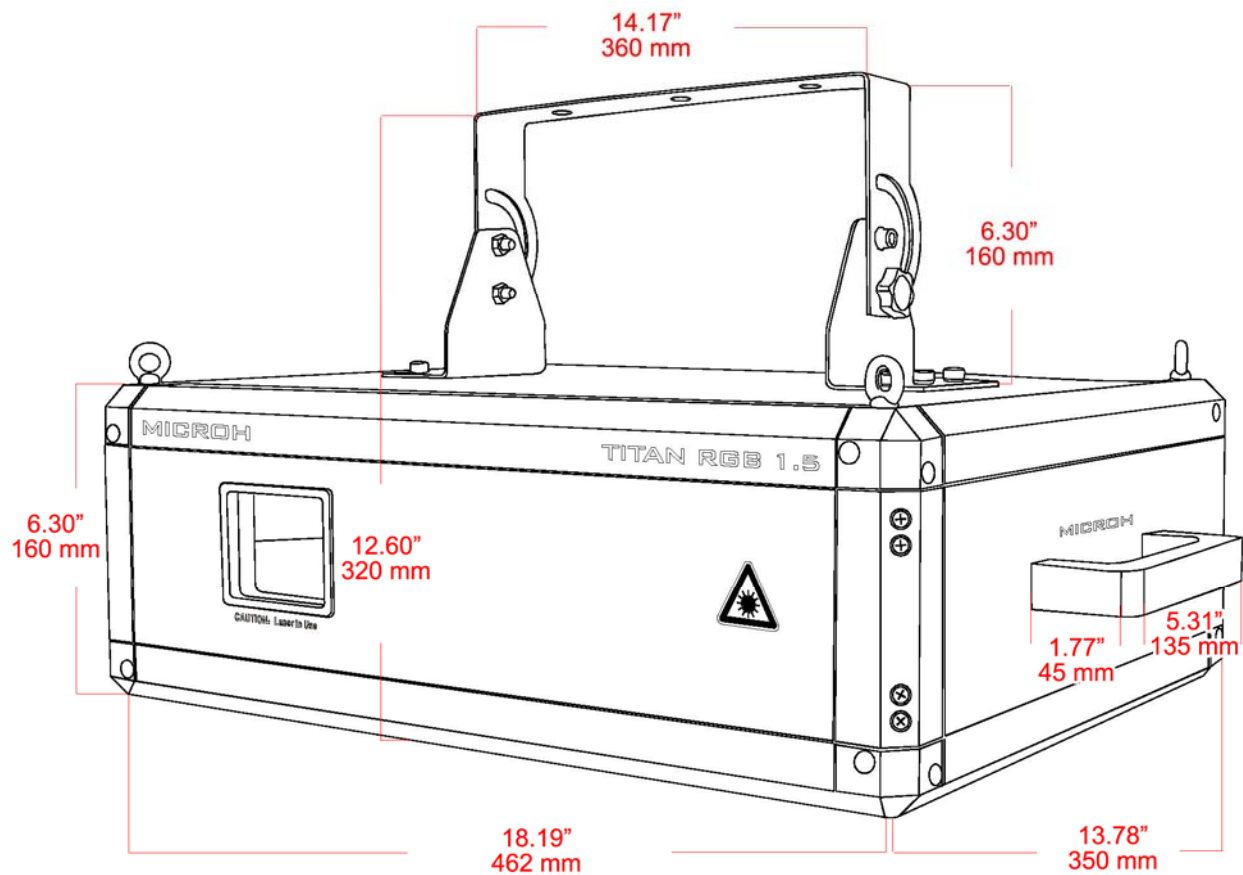

11. MAINTENANCE AND CLEANING

The following points have to be considered during the inspection:

- 1) All screws for installing the device or parts of the device must be tightly connected, and must not be corroded.
- 2) There must not be any deformations on the housing, colour lenses, fixations or installation spots (ceiling, suspension, trussing).
- 3) Mechanically moved parts must not show any traces of wearing and must not rotate with unbalances.
- 4) The electric power supply cables must not show any damage, material fatigue or sediments.

Further instructions depending on the installation spot and usage must be handled by a skilled installer or technician. Any safety issues must be resolved.



In order to keep the fixture in good condition and extend the life, we suggest regular cleaning to the fixture.

- 1) Clean the inside and outside lens each week to avoid the light output from darkening due to accumulation of dust, dirt, etc.
- 2) Clean the fan each week.
- 3) A detailed electrical check by approved technician every three months is advised. Ensure the circuit contacts are in good condition, and prevent from overheating.

We recommend a frequent cleaning of the device. Please use a moist, lint-free cloth. Never use alcohol or solvents.

There are no serviceable parts inside the device. Please refer to the instructions under "Installation instructions".

Should you need any spare parts, please order genuine MICROH parts from your local dealer.

IF YOU SHOULD EXPERIENCE ANY PROBLEMS OR ISSUES PLEASE CONTACT MICROH PROFESSIONAL PRODUCTS BY EMAIL AT info@microhpro.com

In the event that your unit is defective in any way, please contact your local dealer to obtain an RA number for service repair.

DISCLAIMER – MICROH believes that the information contained within this user manual is accurate. However, Microh is not responsible for any error or addendums to this manual. If you have any comments or general suggestions on how this manual can be improved please contact info@microhpro.com. Thank you.

MICROH
PROFESSIONAL PRODUCTS

www.microhpro.com