

USER MANUAL

PHOENIX-RGY

ENGLISH INDEX

1)Open the box for checking	Page 1
2)Installation	Page 1
3)Attention	Page 2
4)Warning	Page 2
5)Structure of the fixture	Page 3
6)Scan motor Replacement	Page 4
7)Adjustable mirror holder	Page 5
8)Laser diode replacement	Page 6
9)Control board instruction	Page 7
10)DMX512 Operate	Page 8
11)Specification	Page 9
12)Maintain	Page 9
13)Electrical diagram	Page 10
14)Trouble shooting	Page 11

Please read over this manual before operation the light

1. Open the box for checking

In order to use this product safely and reasonably for the users, please read over this manual carefully before use and the operation must strictly according to this manual to avoid any damage to the product and personal safety.

Once after received this products please take and put carefully. And check carefully that whether the product was damaged or not during the transportation and please check the following things were enclosed:

- | | |
|--------------------------|-----------------------|
| 1. 1 unit laser light | 1. 1 unit laser light |
| 3. 1pc Pin3 signal cable | 4. 1pc user manual |

2. Installation

1. Please check the voltage whether is the same with the one showed on the equipment or not.
2. It must ask for the technical person and set the light safety when installation. And let the light beam at the suitable angle.
3. When install this equipment please make sure there's no flammable surfaces (decorated things, etc) within at least 1.5M and maintain minimum distance of 0.5M from the equipment to the walls.
4. Please make sure that there's no other equipment or decorating materials obstructed the exhaust fan and the vent-pipe.
5. Products should be install immobility.
6. In case of safety, it's very important that to connect the earth with line.

3. ATTENTION

- Please do not open the bottom cover yourself without permission. Operate it accord the user manual. Please call the technician in case the machine broken down.
- Do not use it under the damp and rain.
- Pay attention to prevent the light from strong bump.
- Prevent the dust into the product
- Keep the vent-pipe well while working.
- Keep the plug insert well before put into power.
- Don't look the light directly to prevent make some destroy with eyes.
- Don't light or extinguish frequently, otherwise the life span of the light tube will be shortened.
- In view of the special characters, after operated the light an hour the product shall be paused about 15 minutes before be used next time.
- Keep the space between light equipments and the lighted things more than one meter.
- Don't touch the product and draw the power line if you hand wet.
- Don't open the cover for there have no parts the user can repair.
- Don't operate the light without lamps.
- If the semiconductor laser doesn't as light as before or there have some destroy with lens or other parts, please contact the distributor in time.
- When you want to retransfer the products, you'd better use the original package to shockproof.

4. Maintain

- Please use cotton stick dipped alcohol to wipe the mirrors at regular. Do not use the wet cloth or chemical impregnant to clean the mirrors.
- Please use the soft cloth to clean the surface of product.

ATTENTION: Disconnect input power before maintain.

Don't look straight at the light sources.

NOTE: Don't separate laser machine from laser power and repair them by yourself otherwise no good repair service will be supplied.

5. Structure of the fixture

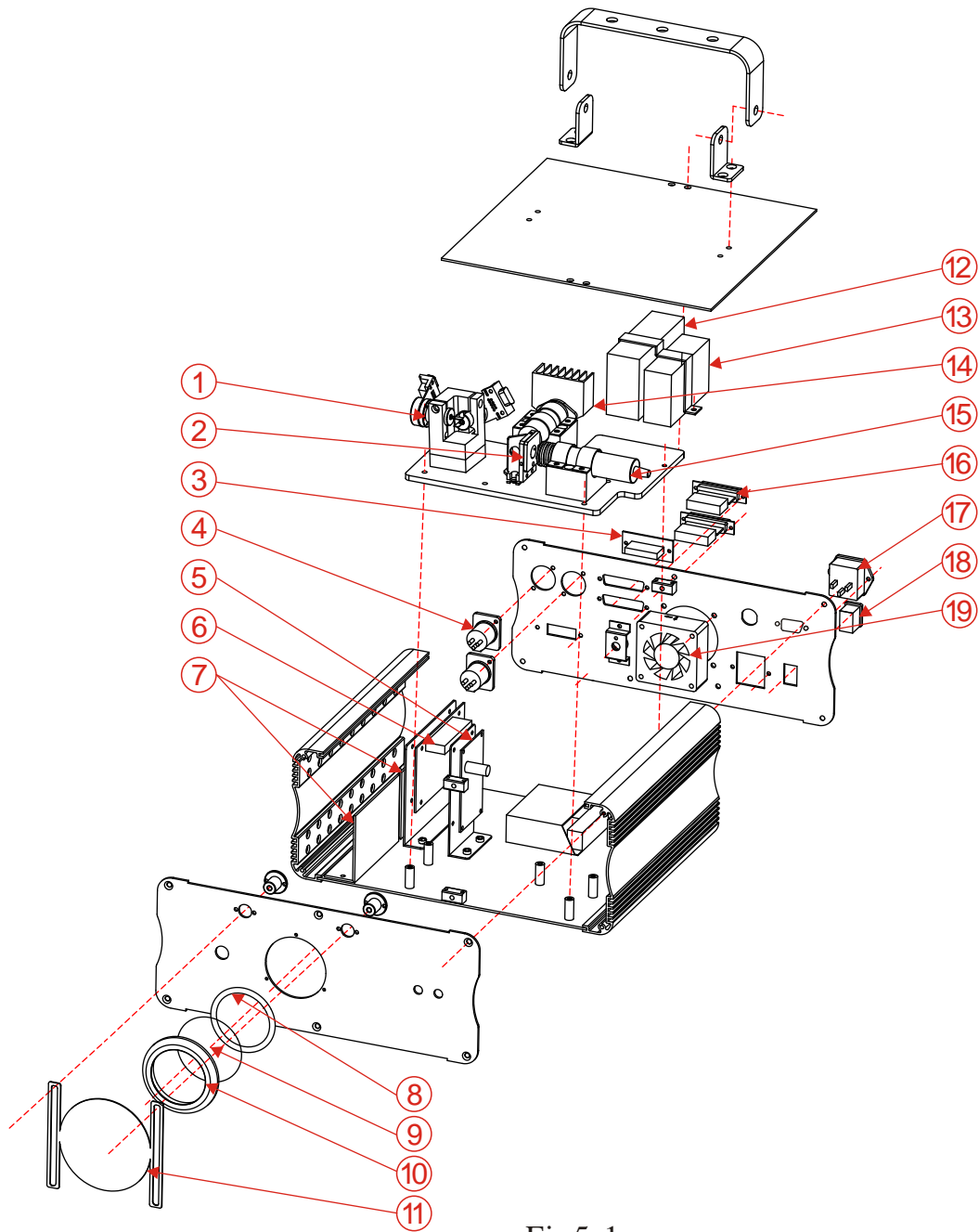

Fig5-1

No.	Description.
1	Scan mirror
2	Adjustable mirror stand
3	Address code PCB
4	DMX plug signal
5	Code board
6	Signal switch PCB
7	X,Y scan board
8	Washer
9	Dustproof mirror
10	Lens holder

No.	Description.
11	shutter
12	Power supply of red laser diode
13	Power supply of green laser diode
14	Green laser diode
15	Red laser diode
16	Male ILDA25 plug
17	Power input plug
18	Power switch
19	Fan

6. Scan motor Replacement

(1) Steps:

1. Unscrew UK M6 screw and plug out male signal connector.
2. Disassemble all M4×10 screw from X,Y scanner socket so that scan motors can be took out, put in and rotate scanner socket to adjust the scan angle.
3. After adjust ,fix M4×10 screws,plug in male signal connector and then fixUK M6 screws.

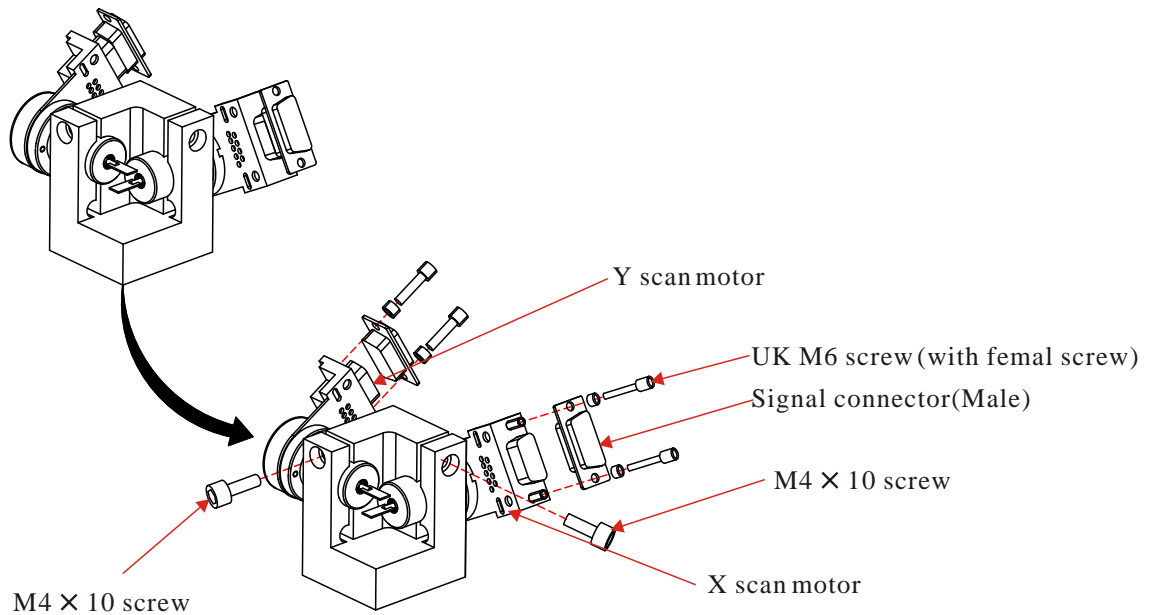

Fig6-1 Scan motor install diagram

(2) Optical system:

RGB mix beam be reflected out by X,Y scan mirrors.

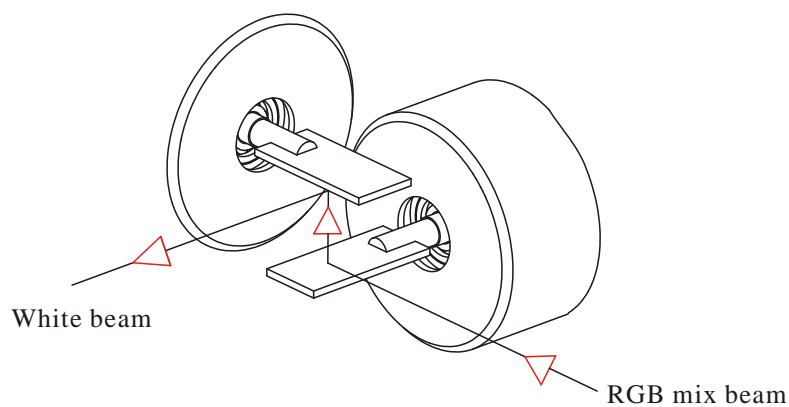

Fig6-2 Optical System diagram

7. Adjustable mirror socket

(1) Steps

1. Loose setscrew of X,Y and then adjust mirror socket to suitable position by X,Y adjustable screws.
2. Adjust Z adjustable screw at same time.
3. Fix X,Y setscrew.

NOTE:Make sure all beams through adjustable mirror socket be one point when you adjust X,Y,Z line with adjustable screw.

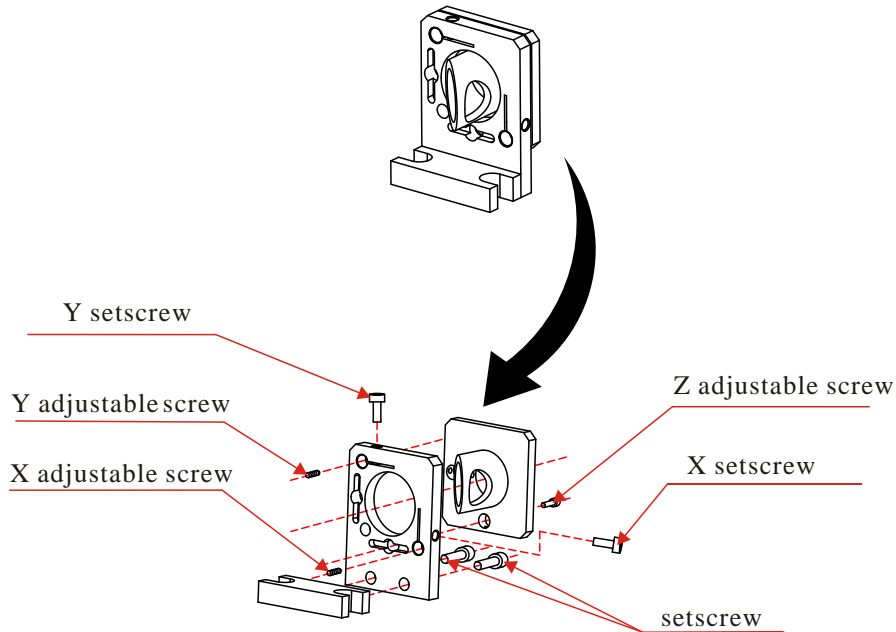

Fig7-1 Adjustable mirror socket structure

(2) RGB Laser beams mix system:

Mirror socket 1: Transmit red beam, reflect green beam, and then mix out yellow beam through mirror socket 1.

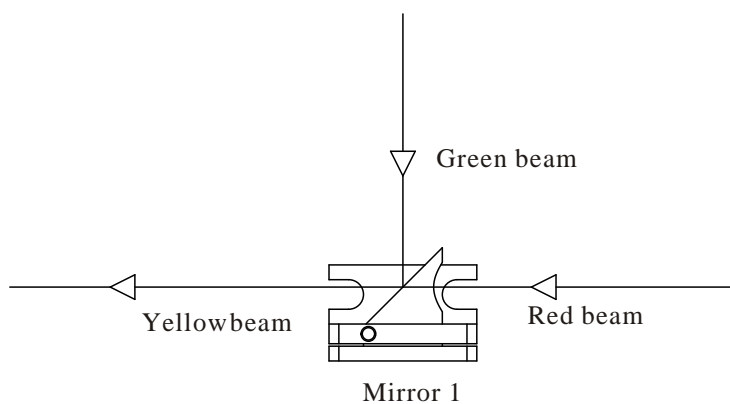

Fig7-2 RGY laser beams mix system

8. Laser diode replacement

Methods:

Disassemble whole laser system (include power supply, laser diode) and then replace new one at original position.

Note: keep laser diode, power supply and cables be completely and don't try to damage, destroy or cut them so that it can be repaired (crefer fig8-1).

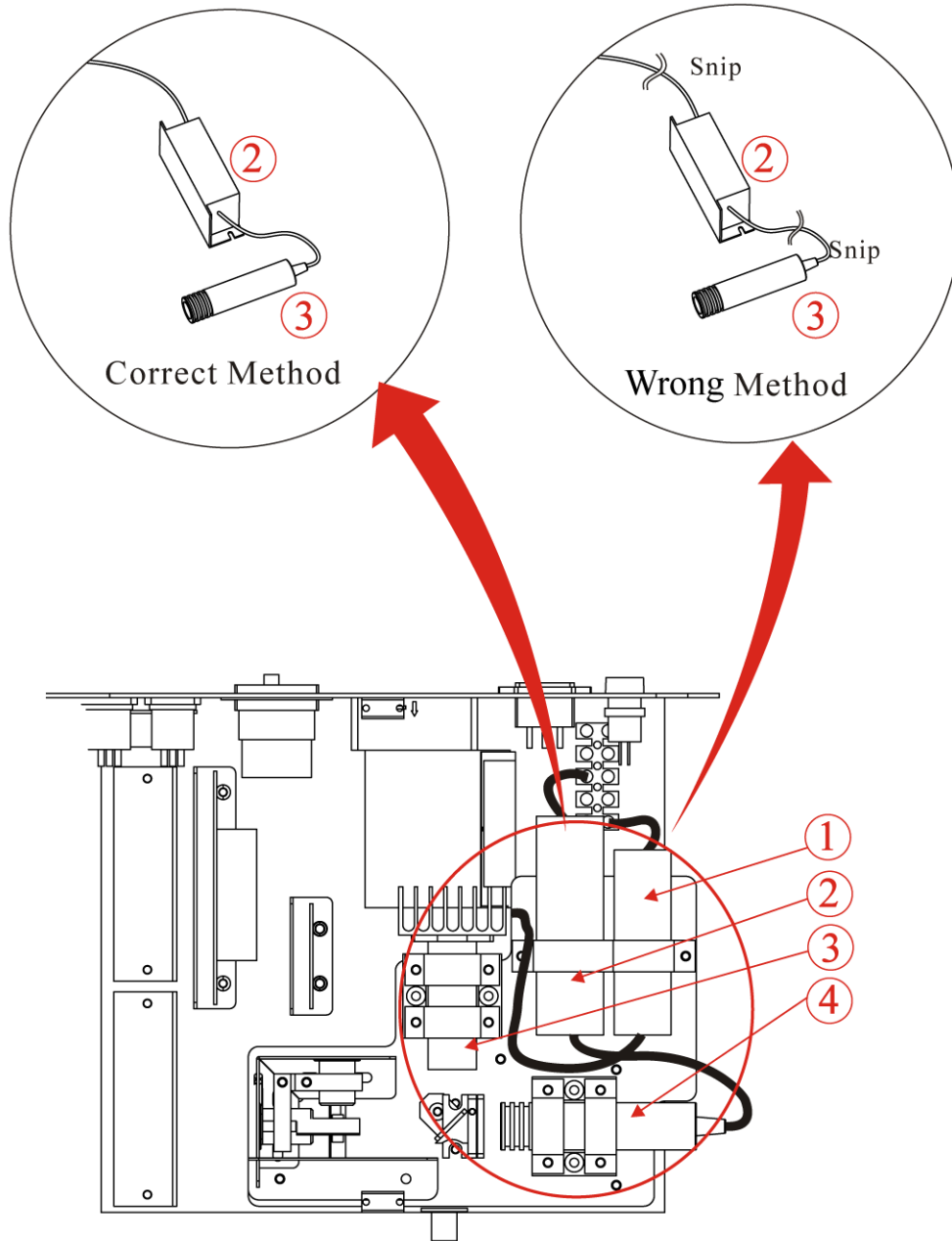
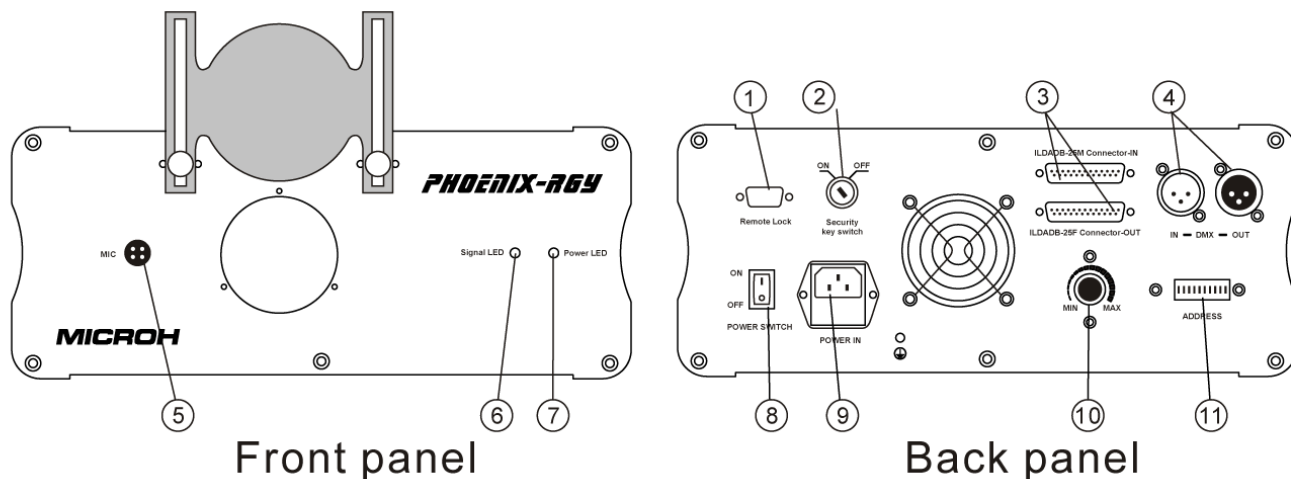

Fig8-1

①	power supply of green laser diode	③	red laser diode
②	power supply of red laser diode	④	Green laser diode

9. Control board instruction



①	Remote Lock: In the event of removal, laser will not emit any beam.(E.U. IEC regulation)
②	Security key switch: Power switch
③	ILDA DB 25 F Connector: signal input connection port of the laser perform software that in accordance with the ILDA standard.
④	DMX IN/OUT: International standard DMX512 signal input/output
⑤	MIC: Sound receiver
⑥	Signal LED: Signal LED
⑦	Power LED: Power LED
⑧	POWER SWITCH: Power switch
⑨	POWER IN: Power cord, fuse inside
⑩	MIN—MAX: Sound control
⑪	ADDRESS: Address code switch. The 10th code is switch code. If the 10th code is OFF, the 1-9 codes are function code. If the 10th code is ON, the fixture can be controlled by DMX512 signal and other codes are DMX address codes. Please refer to following two pictures about setting.

Function code setting:

Function	Address switch																				
Music mode	<table border="1"> <tr><td>1</td><td>2</td><td>3</td><td>4</td><td>5</td><td>6</td><td>7</td><td>8</td><td>9</td><td>10</td></tr> <tr><td>OFF</td><td>OFF</td><td>OFF</td><td>OFF</td><td>OFF</td><td>OFF</td><td>OFF</td><td>OFF</td><td>OFF</td><td>ON</td></tr> </table>	1	2	3	4	5	6	7	8	9	10	OFF	OFF	OFF	OFF	OFF	OFF	OFF	OFF	OFF	ON
1	2	3	4	5	6	7	8	9	10												
OFF	OFF	OFF	OFF	OFF	OFF	OFF	OFF	OFF	ON												
Auto mode	<table border="1"> <tr><td>1</td><td>2</td><td>3</td><td>4</td><td>5</td><td>6</td><td>7</td><td>8</td><td>9</td><td>10</td></tr> <tr><td>OFF</td><td>OFF</td><td>OFF</td><td>OFF</td><td>OFF</td><td>OFF</td><td>OFF</td><td>OFF</td><td>OFF</td><td>ON</td></tr> </table>	1	2	3	4	5	6	7	8	9	10	OFF	OFF	OFF	OFF	OFF	OFF	OFF	OFF	OFF	ON
1	2	3	4	5	6	7	8	9	10												
OFF	OFF	OFF	OFF	OFF	OFF	OFF	OFF	OFF	ON												
Slave mode	<table border="1"> <tr><td>1</td><td>2</td><td>3</td><td>4</td><td>5</td><td>6</td><td>7</td><td>8</td><td>9</td><td>10</td></tr> <tr><td>OFF</td><td>OFF</td><td>OFF</td><td>OFF</td><td>OFF</td><td>OFF</td><td>OFF</td><td>OFF</td><td>OFF</td><td>ON</td></tr> </table>	1	2	3	4	5	6	7	8	9	10	OFF	OFF	OFF	OFF	OFF	OFF	OFF	OFF	OFF	ON
1	2	3	4	5	6	7	8	9	10												
OFF	OFF	OFF	OFF	OFF	OFF	OFF	OFF	OFF	ON												

Switch for DMX control mode. The setting in the picture is DMX signal unacceptable..

DMX code setting:

Algorithm	Binary code LSB → MSB	Address switch																				
1	10000000	<table border="1"> <tr><td>1</td><td>2</td><td>3</td><td>4</td><td>5</td><td>6</td><td>7</td><td>8</td><td>9</td><td>10</td></tr> <tr><td>OFF</td><td>OFF</td><td>OFF</td><td>OFF</td><td>OFF</td><td>OFF</td><td>OFF</td><td>OFF</td><td>OFF</td><td>ON</td></tr> </table>	1	2	3	4	5	6	7	8	9	10	OFF	OFF	OFF	OFF	OFF	OFF	OFF	OFF	OFF	ON
1	2	3	4	5	6	7	8	9	10													
OFF	OFF	OFF	OFF	OFF	OFF	OFF	OFF	OFF	ON													
14	01110000	<table border="1"> <tr><td>1</td><td>2</td><td>3</td><td>4</td><td>5</td><td>6</td><td>7</td><td>8</td><td>9</td><td>10</td></tr> <tr><td>OFF</td><td>OFF</td><td>OFF</td><td>OFF</td><td>OFF</td><td>OFF</td><td>OFF</td><td>OFF</td><td>OFF</td><td>ON</td></tr> </table>	1	2	3	4	5	6	7	8	9	10	OFF	OFF	OFF	OFF	OFF	OFF	OFF	OFF	OFF	ON
1	2	3	4	5	6	7	8	9	10													
OFF	OFF	OFF	OFF	OFF	OFF	OFF	OFF	OFF	ON													
27	11011000	<table border="1"> <tr><td>1</td><td>2</td><td>3</td><td>4</td><td>5</td><td>6</td><td>7</td><td>8</td><td>9</td><td>10</td></tr> <tr><td>OFF</td><td>OFF</td><td>OFF</td><td>OFF</td><td>OFF</td><td>OFF</td><td>OFF</td><td>OFF</td><td>OFF</td><td>ON</td></tr> </table>	1	2	3	4	5	6	7	8	9	10	OFF	OFF	OFF	OFF	OFF	OFF	OFF	OFF	OFF	ON
1	2	3	4	5	6	7	8	9	10													
OFF	OFF	OFF	OFF	OFF	OFF	OFF	OFF	OFF	ON													

Switch for DMX control mode. The setting in the picture is DMX signal acceptable

10. DMX512 Operate

The fixture have 14 DMX channels. The following is function list:

Channel		Value	Function
1	Control mode	0~63	Auto-Music mode(Channel 1&2 valid)
		64~127	Auto- mode(Channel 1&2 valid)
		128~191	Music-edit mode(All channel valid)
		192~255	Mannle-edit mode(All channel valid)
2	Colour	0~41	Open
		42~83	Red
		84~125	Yellow
		126~167	Green
		168~209	R.G.Y color change
		210~251	Color flow
		252~255	No beam
3	Gobo group	0~42	Gobo group 1: 32gobos
		43~85	Gobo group 2: 32gobos
		86~128	Gobo group 3: 32gobos
		129~171	Gobo group 4: 32gobos
		172~214	Gobo group 5: 32gobos
		215~255	Gobo group 6: Cartoons(4 sequency)
4	Gobo change	0~255	32 gobos (0~255)/8=(0~31)
			4 sequency (0~255)/8=(0~31)
5	Speed	0~255	12 class speed (0~255)/23=(0~11)(from slow to fast)
6	Rotate	0~63	No function
		64~127	Horizontal rotating
		128~191	Vertical rotating
		192~255	Horizontal & Vertical rotating
7	Dot Rotating	0~63	No function
		64~127	Rotating
		192~255	Rotating & Dotting
8	Move	0~63	No function
		64~127	Horizontal movement (Y line)
		128~191	Vertical movement (X line)
		192~255	Horizontal & Vertical movement
9	Extend	0~63	No function
		64~127	Extending in Horizontal
		128~191	Extending in Vertical
		192~255	Extending in Horizontal & Vertical
10	Zoon	0~85	No function
		86~169	Zoom from small to large
		170~255	Zoom from large to small
11	Drawing speed	0~255	255 class speed (from slow to fast)
12	Scan speed	0~255	255 class speed (from fast to slow)
13	Colour speed	0~255	255 class speed (from fast to slow)
14	Size	0	Original size
		1~255	42 class size (1~255)/6=(0~42) 1~19 smaller 20 original size 21~42 enlarge

11. Specification

- Voltage: AC 220V~240V, 50/60Hz
- Total power: 25W
- Scanner: Simple scanner
- Cooling mode: Air cooling
- Scan angel : $0\sim\pm 30^\circ$
- DMX Channel: 14 CHS
- Laser light power: Red Laser Class 3B 635nm
Green Laser Class 3B 532nm
- Control mode: Musci mode, Auto-mode, Master/slave mode, DMX512
- Net weight: 6 kg
- Dimension: 320 x 270 x 130 mm

12. Maintain

- Maintenance should be performed every 15-day period, by using a sponge which is dipped with alcohol, rather than wet cloth or other chemical liquid, to clean the mirror.
- Warning: Power must be disconnected before maintenance or repair. Do not look at the light source directly.
ATTENTION: DISCONNECT INPUT POWER BEFORE MAINTAIN.
DON'T LOOK STRAIGHTLY AT THE LIGHT SOURCES.
NOTE: Don't seperate laser machine from laser power and repaire them by yourself otherwise no good repair service will be supplied.

13. Electrical diagram

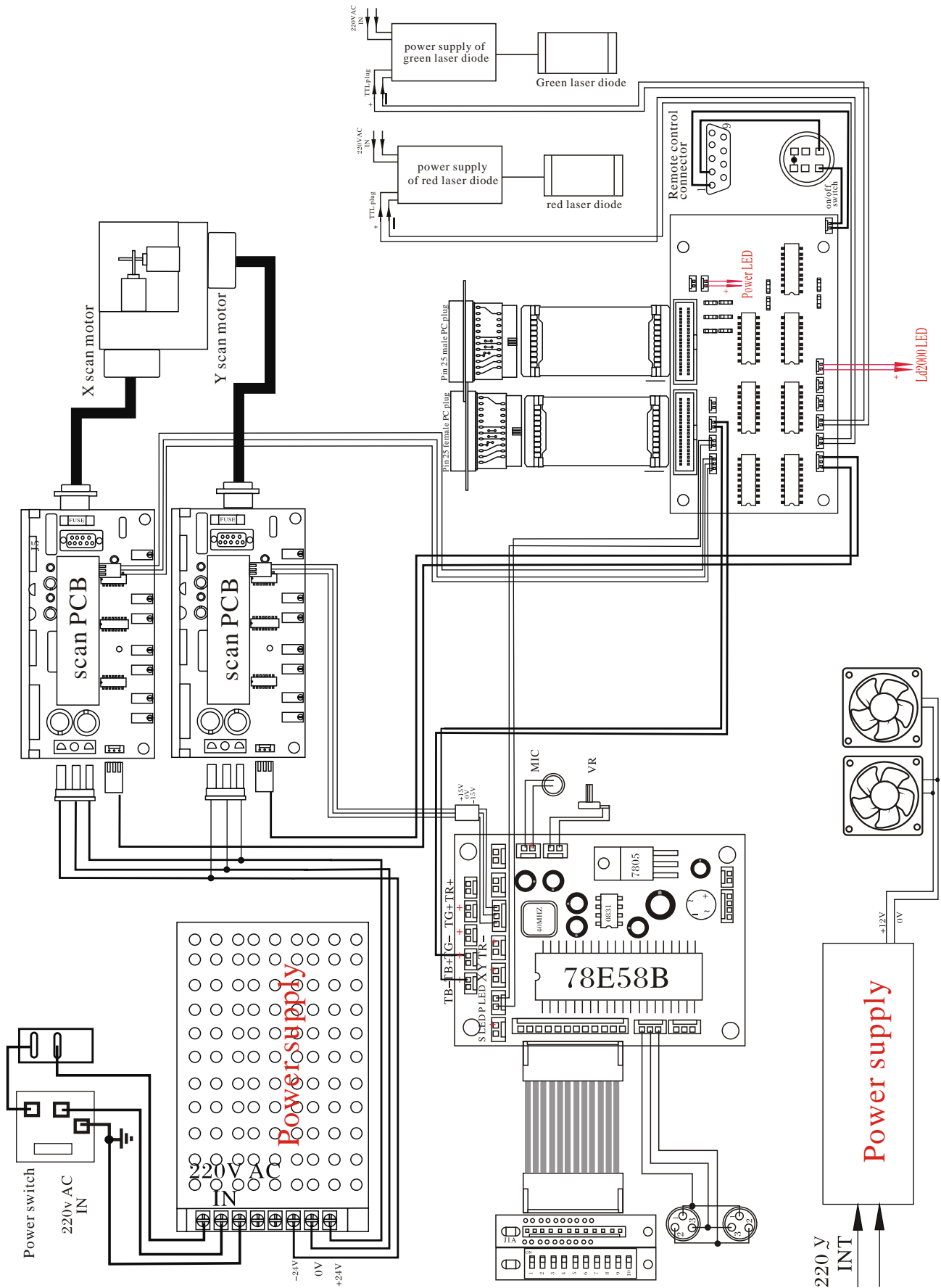

14. Trouble shooting

Problem	Causation	Solution way	Series number
No power to motor	Damaged Fuse	Fuse	09-00-2001-01
	Damaged power supply	$\pm 15V$	16-03-0001-00
No response to music or it is difficult be active by music	Damaged mic	MIC	16-03-0001-00
	Damaged control PCB	Control PCB	26-2A-LT12V2-00
	Damaged potentiometer	Potionmeter	04-03-0104-01
	Damaged 89C516RD IC	89C516RD IC	00-89C516RD-00
X,Y scanner no strength or no pattern or scanner shaking	Damaged scanner	Super scan motor	15-01-2215-00
	Damaged 89C516RD IC	89C516RD IC	00-89C516RD-00
	Damaged control PCB	Control PCB	26-2A-LT12V2-00
	Damaged power supply	$\pm 15V$	16-03-0001-00
	Damaged scan board	Scan board	26-2A-FASTSCAN-00
No beam or beam dim or beam can't close, but other functions OK	Dirty lens	Clear it with alcohol	
	Damaged laser diode	Green laser diode	07-01-0005-08
		Red laser diode	07-03-0080-01
	Damaged control PCB	Control PCB	26-2A-LT12V2-00
Can not control other function OK Such as laser diode and fans	Control mode setting incorrect	Please refer to the usermanual for further instruction	
	Damaged control PCB	Control PCB	26-2A-LT12V2-00
	Damaged power supply	$\pm 15V$	16-03-0001-00
	Damaged address board	T 6 address code board	26-2A-LT6SW-00

Appendix:**ILDA DB 25FPINOUTS DB 25 definens**

1	X+	-5 to +5V
2	Y+	-5 to +5V
3	Intensity/Blanking+	0V to +2.5V
4	Interlock A	Connected to pin 17 inside the Qm2000
5	Red+	0V to +2.5V
6	Green+	0V to +2.5V
7	Blue+	0V to +2.5V
8	Deep blue+	0V to +2.5V
9	Yellow+	0V to +2.5V
10	Cyan+	0V to +2.5V
11	Z+	Depth Z(not intensity), -5 to +5V
12	Not connected	
13	Shutter	0V to +5V
14	X-	-5V to +5V
15	Y-	-5V to +5V
16	Intensity/Blanking-	-2.5V to 0V
17	Interlock B	Connected to pin 4 inside the Qm2000
18	Red-	-2.5V to 0V
19	Green-	-2.5V to 0V
20	Blue-	-2.5V to 0V
21	Deep blue-	-2.5V to 0V
22	Yellow-	-2.5V to 0V
23	Cyan-	-2.5V to 0V
24	Z-	-5V to +5V
25	Ground	Cable shield